

Kergord Access Track

Environmental Appraisal Report

Figures

June 2016

THIS PAGE IS INTENTIONALLY BLANK

**Kergord Access Track
Environmental Appraisal Report Figures**

1: Introduction	Figure 1.1	Site Location
	Figure 1.2	Site Plan
3: Description of Proposed Development	Figure 3.1	Typical Road Cross Sections
	Figure 3.2a/b	Typical Bridge Structure
	Figure 3.3	Typical Culvert Structure
	Figure 3.4	Proposed Construction Compound Layout
4: Environmental Figures	Figure 4.1	Ecological Survey Area Overview
	Figure 4.2	Phase 1 Habitat Survey Results, 2015
	Figure 4.3	National Vegetation Classification Survey Results, 2015
	Figure 4.4	Ground Water Dependent Terrestrial Ecosystems Potential Map, 2015
	Figure 4.5	Otter Survey Results, 2015
10: Geology, Hydrogeology and Hydrology	Figure 4.6	Hydrological Study Area
	Figure 4.7	Hydrological Constraints Map
	Figure 4.8	Superficial Deposits
	Figure 4.9	Geology - Bedrock
	Figure 4.10	Surface Water Catchments
	Figure 4.11	Water Supply Infrastructure
	Figure 4.12	Cultural Heritage Assets

THIS PAGE IS INTENTIONALLY BLANK

Key
 Application Boundary

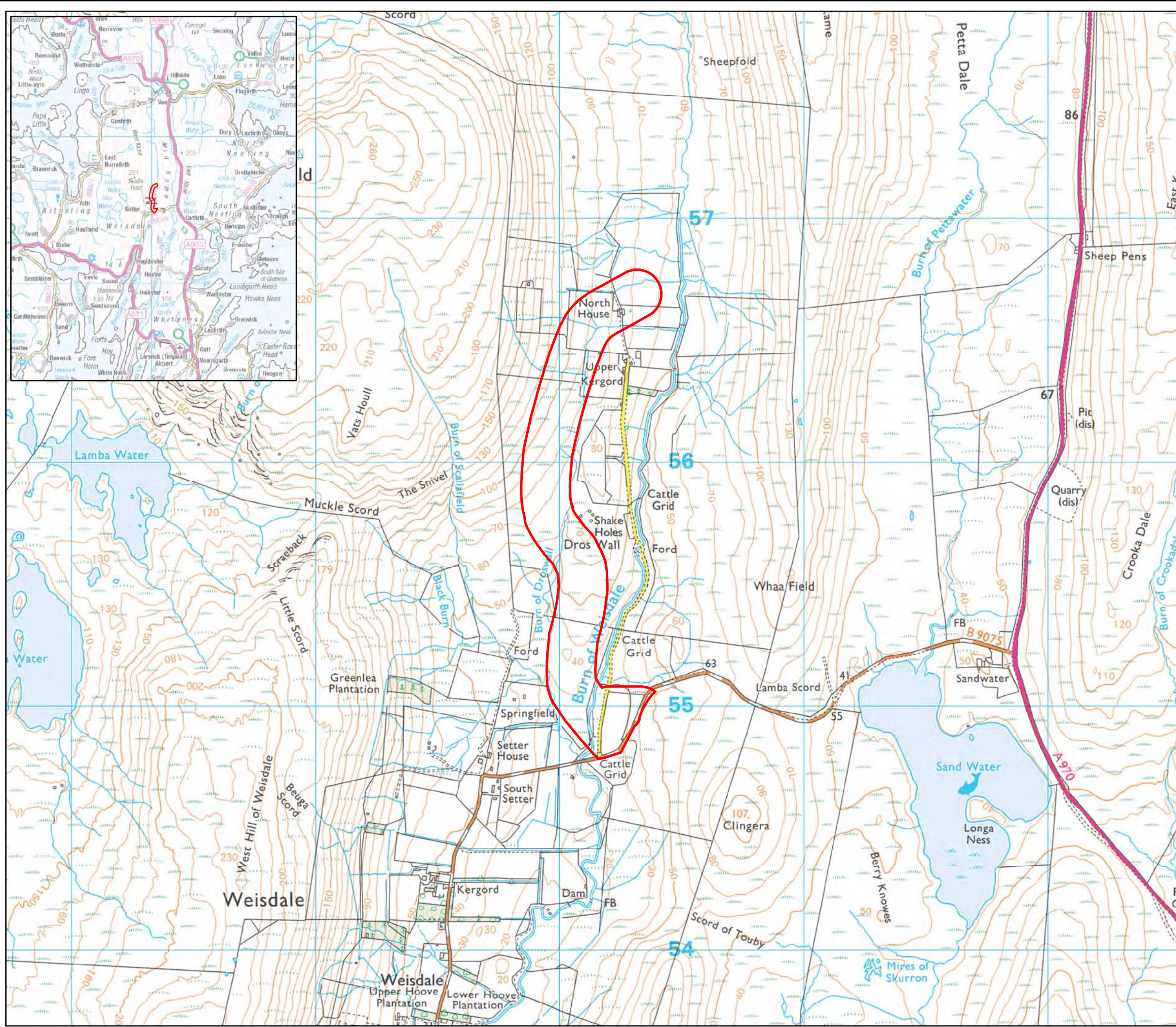







Scale 1:15,000 @ A3

 0 0.1 0.2 0.4 km



Figure 1.1
SITE LOCATION

- Key**
-  Proposed Access Point
 -  Landownership Boundary
 -  Application Boundary
 -  Temporary Construction Compound
 -  Proposed Kergord Access Track
 -  Proposed B9075 Sandwater Road

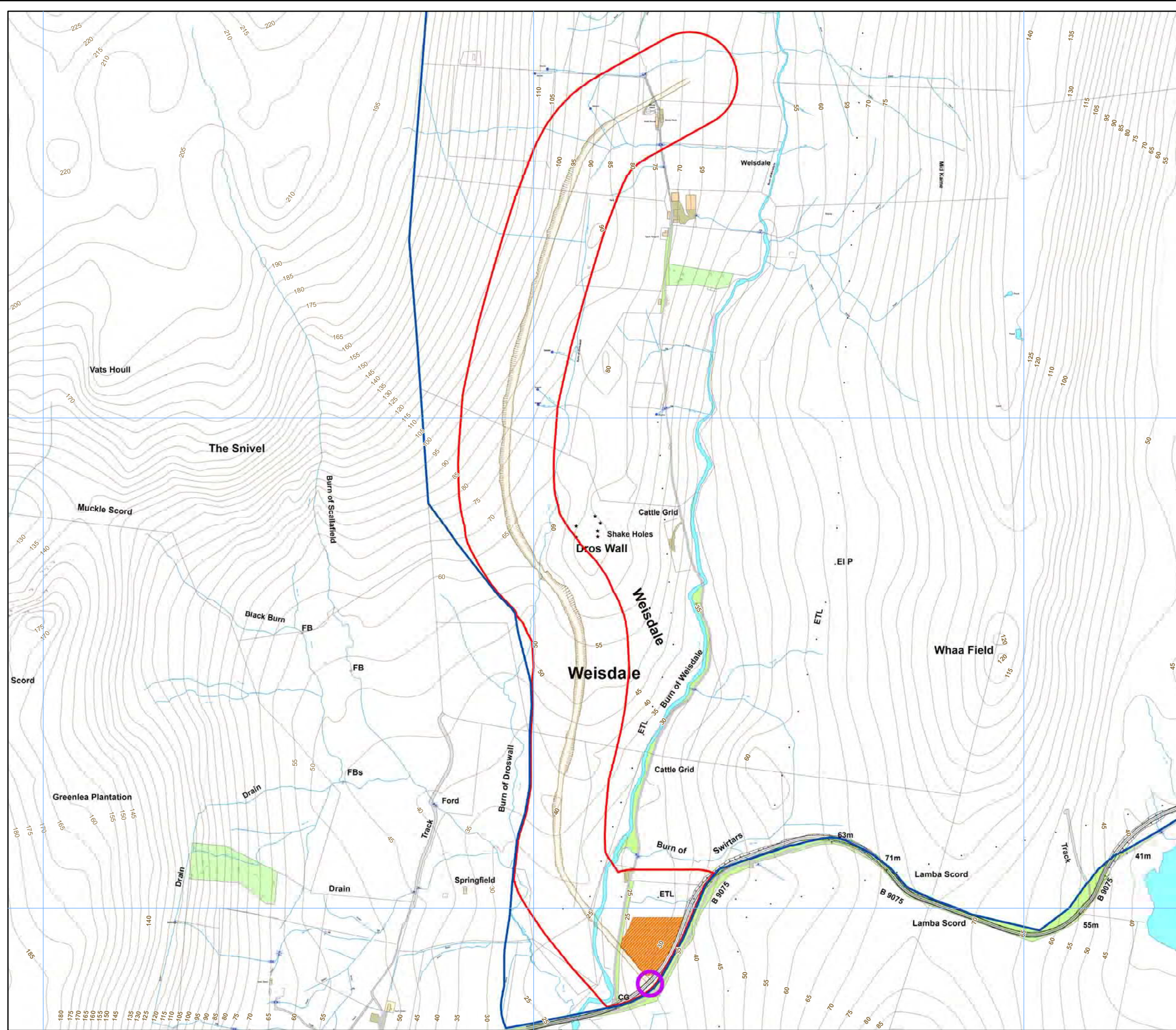

Scale 1:7,500 @ A3

 0 0.05 0.1 0.2 km



Figure 1.2
SITE PLAN

NOTES

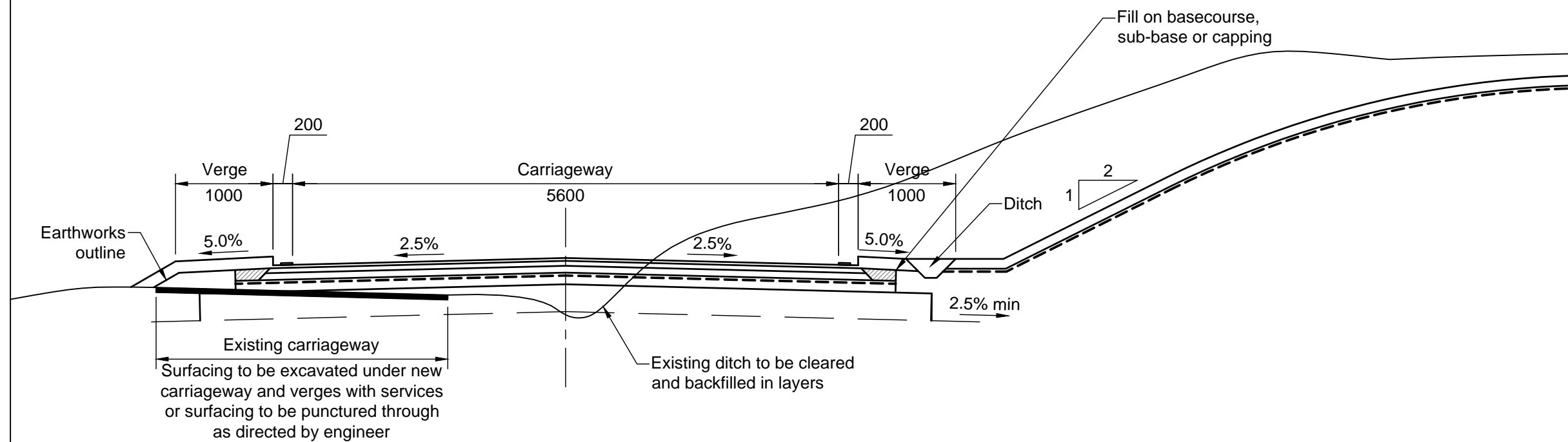
1. All dimensions are in millimetres.
2. Depth of ditch to invert level to vary according to road construction.
3. Carriageway width refers to distance between edge lines.



NORMAL CAMBER SECTION DETAILS

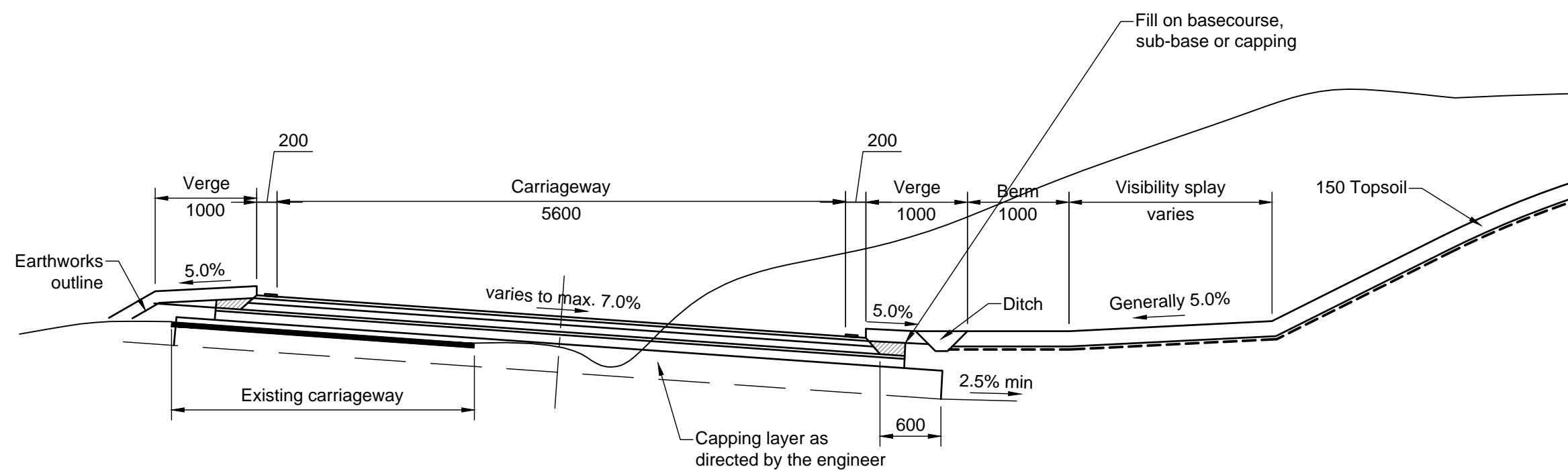

CROSSFALL WITH CURVE WIDENING AND VISIBILITY SPLAY SECTION DETAILS

Scale 1:50 @ A3



Figure 3.1a
Typical Road Cross Section

NOTES

1. All dimensions are in millimetres.
2. Carriageway width refers to distance between edge lines.

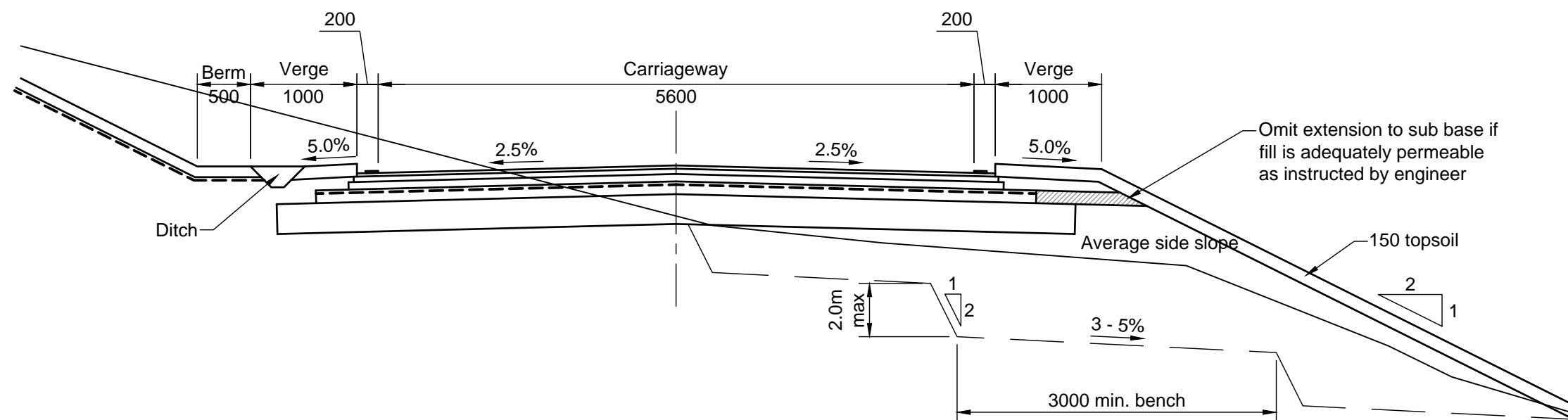

NORMAL CAMBER WITH BENCHING FOR FILLING
ON SIDE LONG GROUND SECTION DETAILS

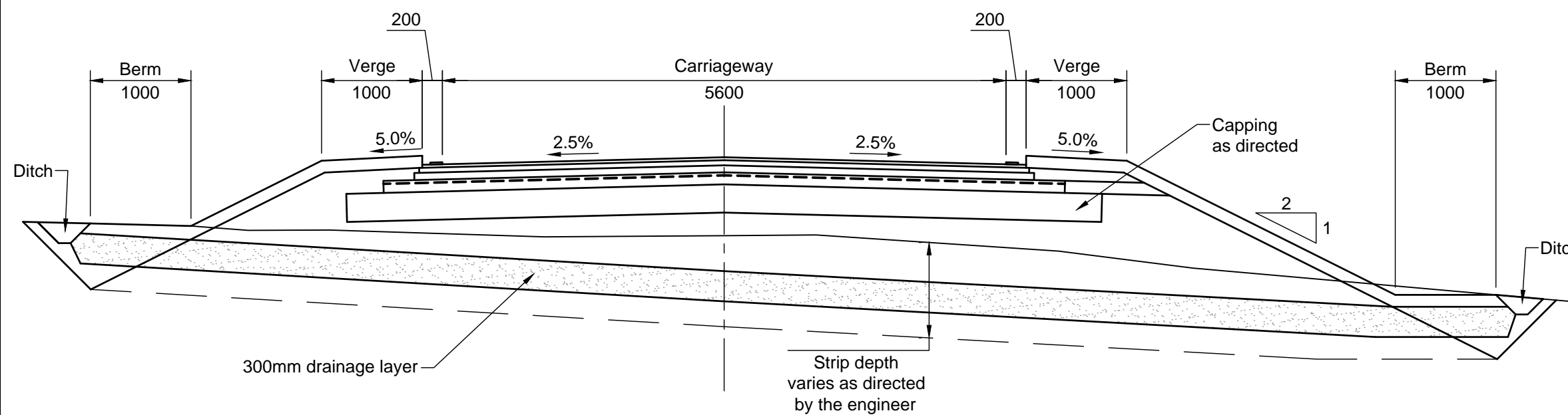

NORMAL CAMBER ON EMBANKMENT SECTION DETAILS

Scale 1:50 @ A3

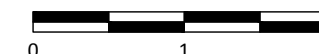
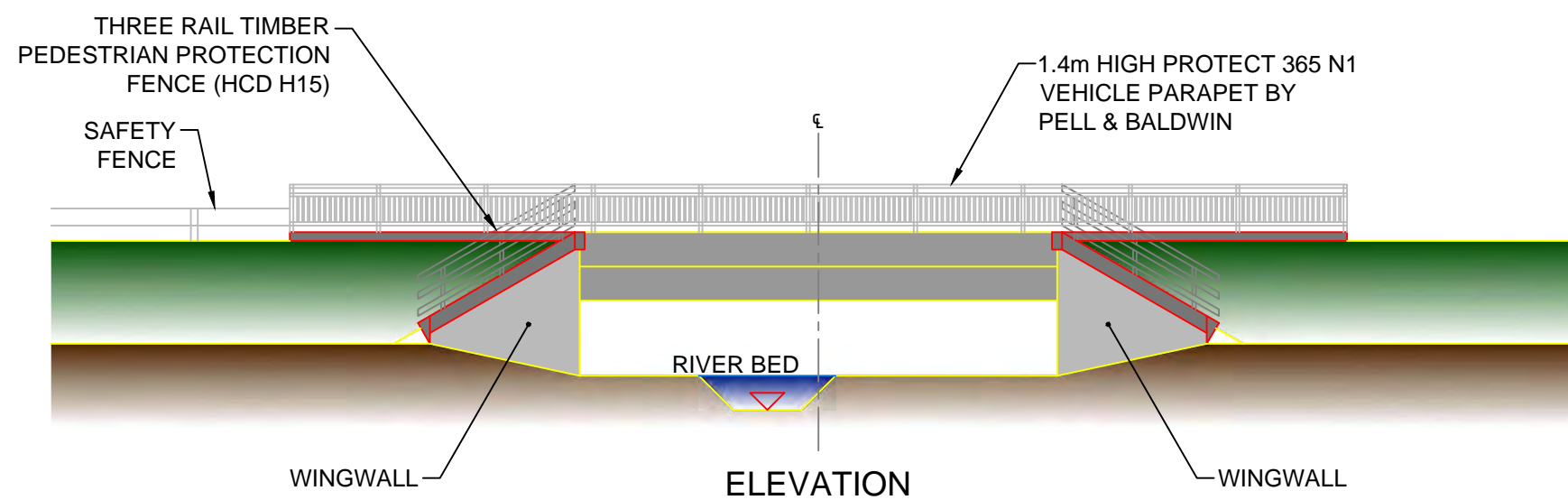
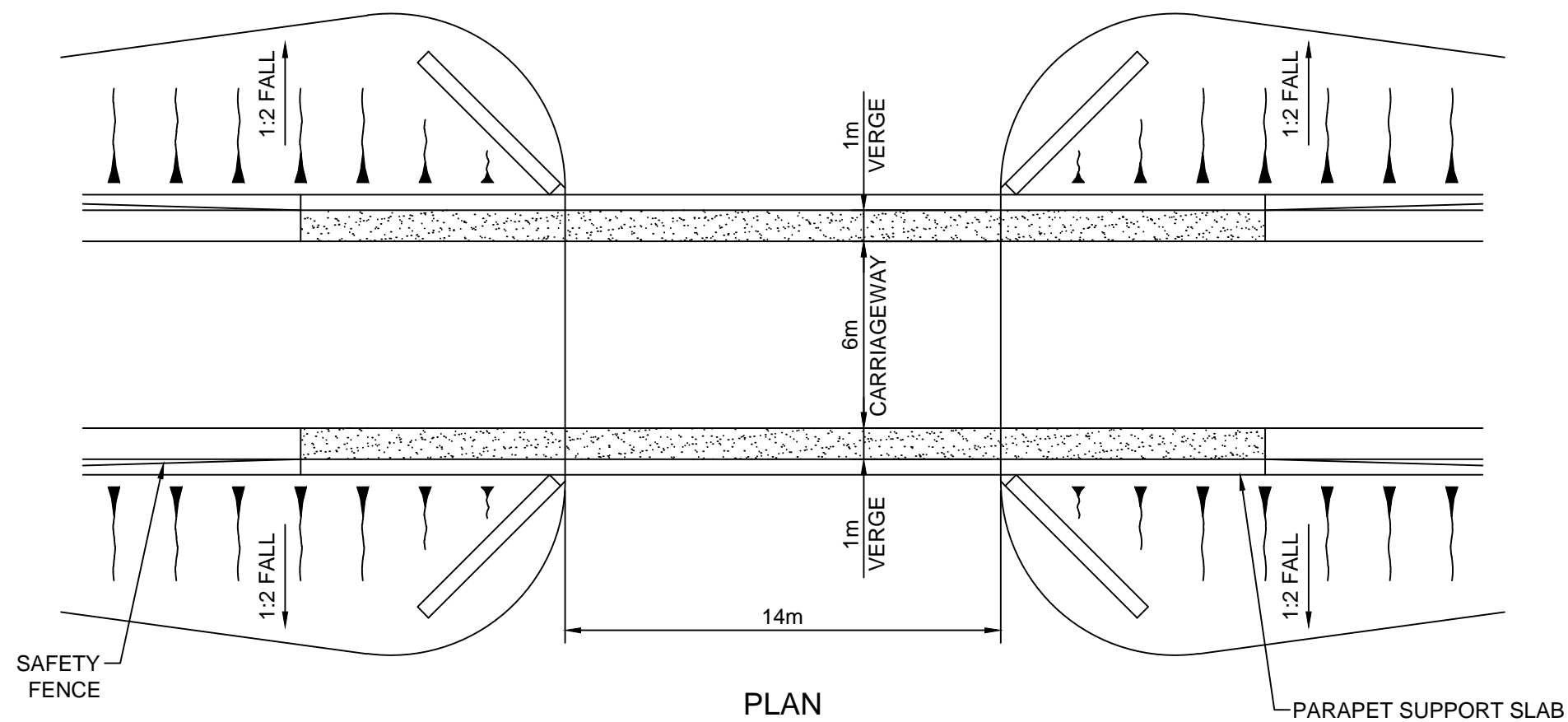

Figure 3.1b
Typical Road Cross Section



NOTES

1. Subject to final detailed engineering design.

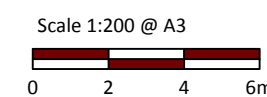
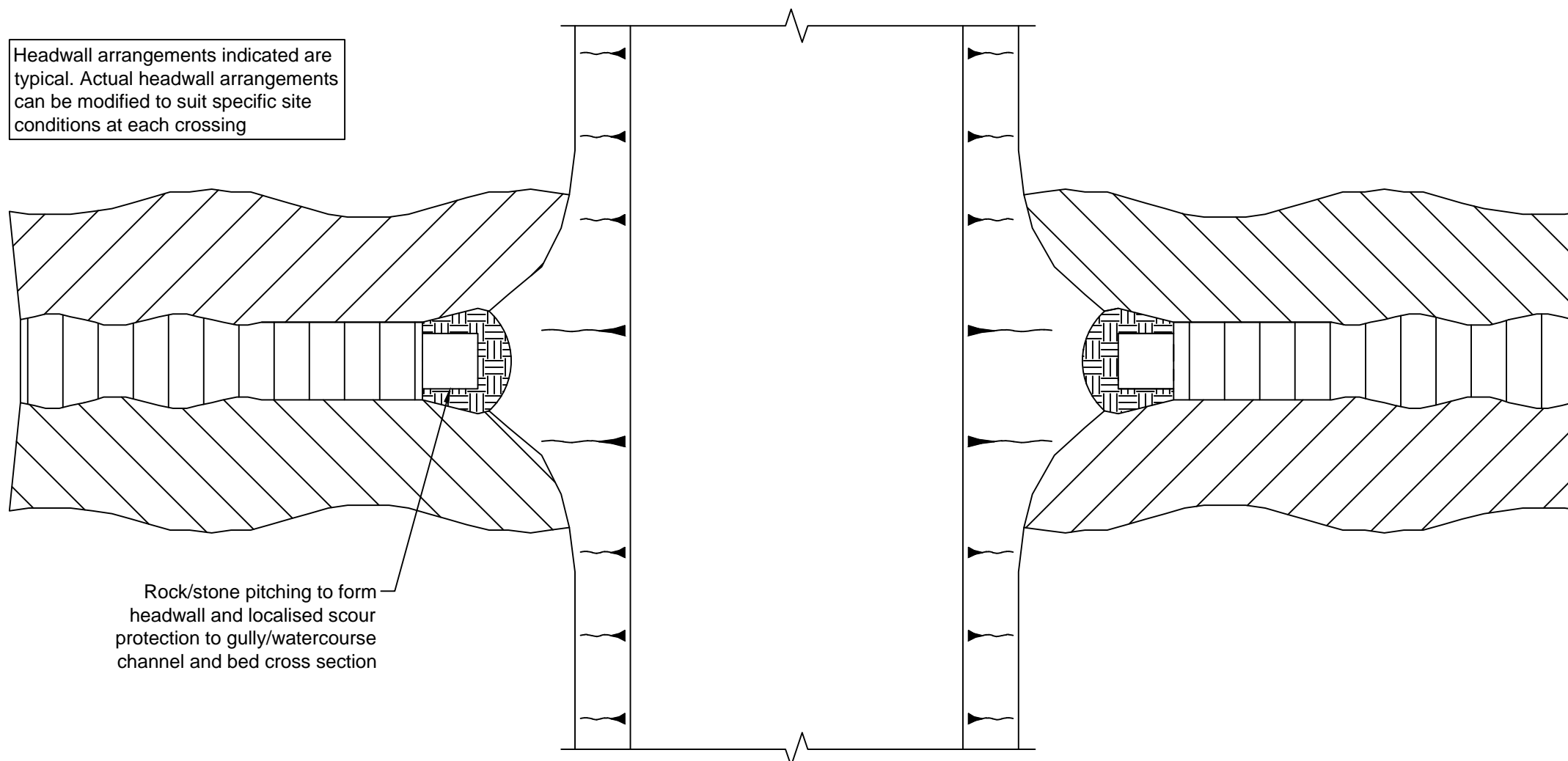

Figure 3.2
Typical Bridge Structure

NOTES

1. New culverts shall be positioned such as to depress the culvert invert between a $\frac{1}{4}$ and a $\frac{1}{3}$ of the pipe diameter below the existing stream bed level.
2. Track side drainage ditches will not discharge directly into the watercourses. Sediment control measures will be used during construction and maintenance works.
3. Contractor to give consideration to the final land form at new culvert inlet and outlets. Batter slopes to be shallow to aid future access and maintenance of culverts.
4. Contractor to give consideration to culvert type and material to provide the adequate strength characteristics to withstand the applied axle loads from both Construction and Turbine Delivery Vehicles.
5. Subject to final detailed engineering design.

Headwall arrangements indicated are typical. Actual headwall arrangements can be modified to suit specific site conditions at each crossing



Rock/stone pitching to form headwall and localised scour protection to gully/watercourse channel and bed cross section

Typical Plan on New Watercourse Crossing

Scale 1:100

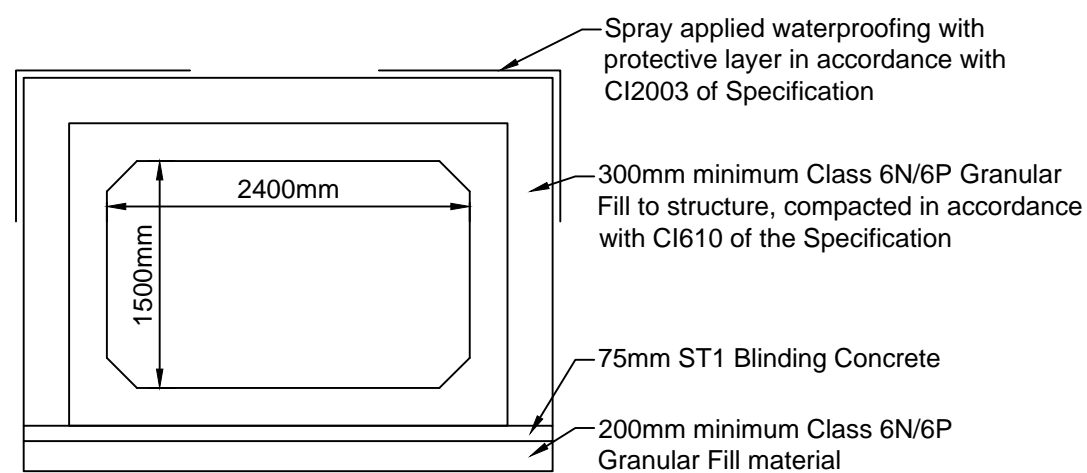

Cross Section through Box Culvert Showing Bedding & Surround Arrangement

Scale 1:50

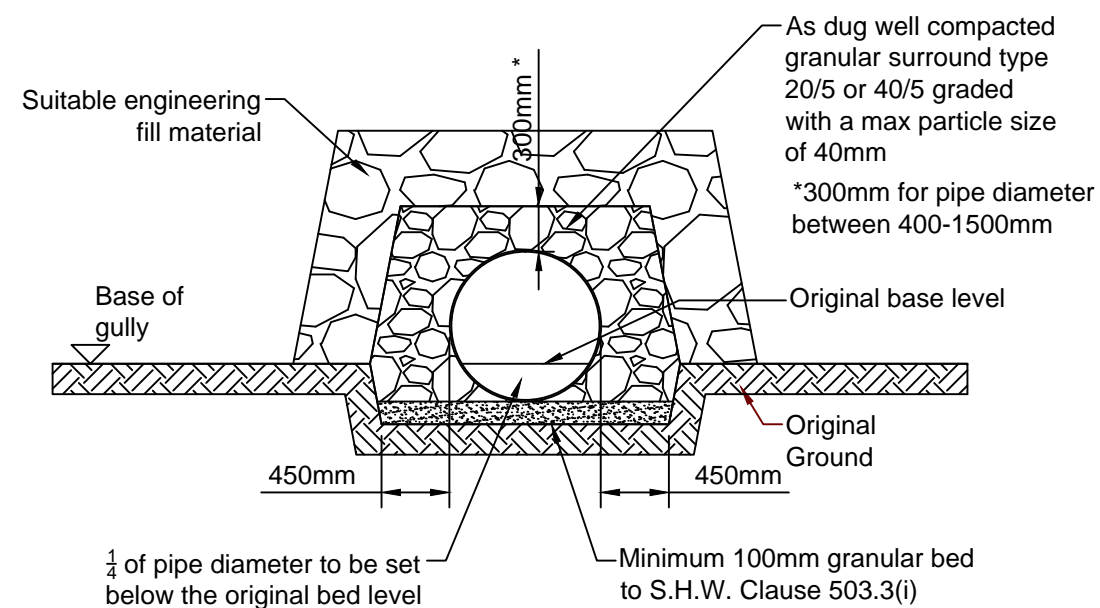

Section B-B



Typical Cross Section through New Watercourse Showing Bedding & Surround Arrangement

Scale 1:50

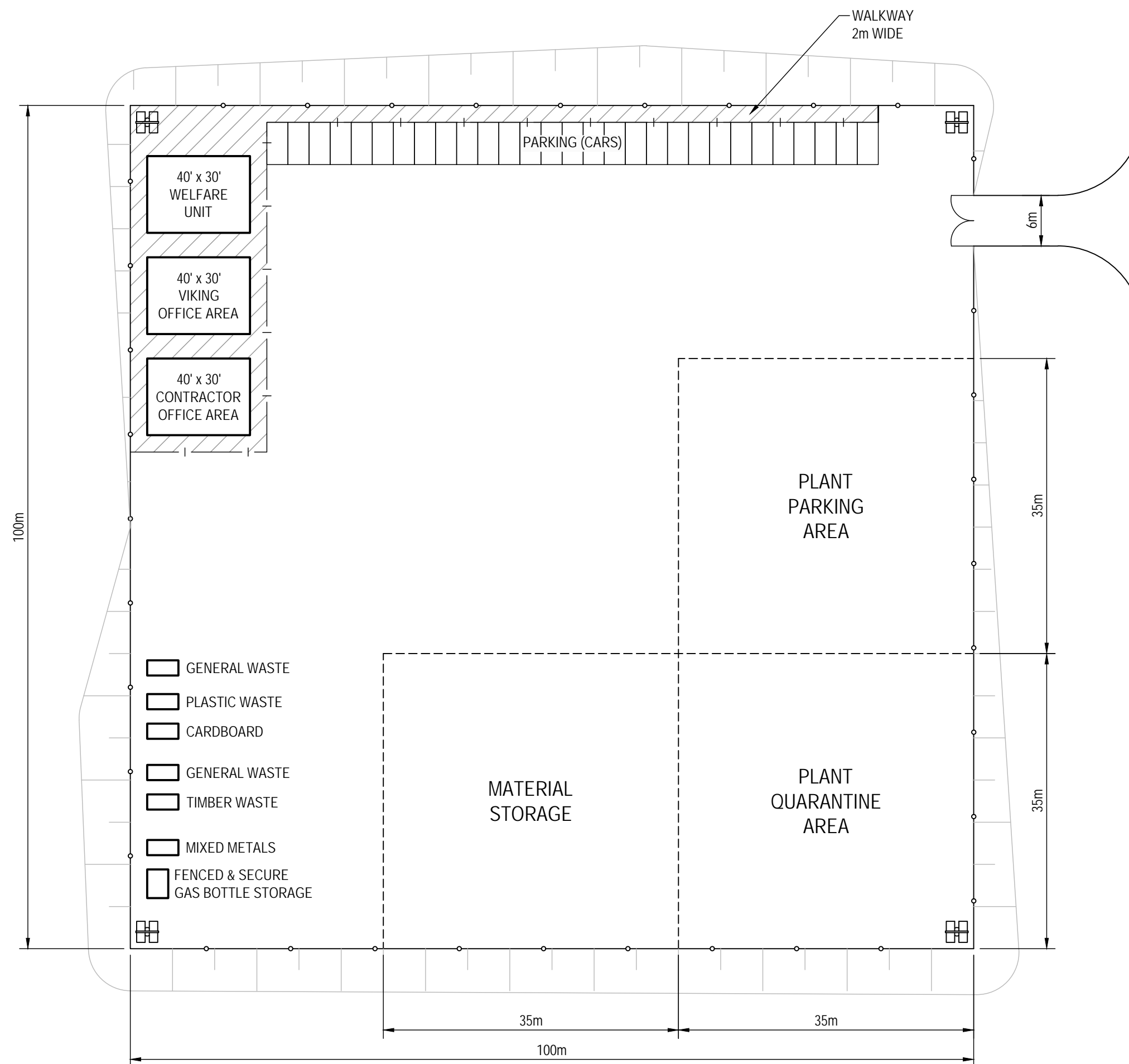
Figure 3.3 Typical Culvert Structure

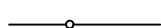

LEGEND

-  SECURITY FENCE
-  PEDESTRIAN FENCE
-  FLOOD LIGHT

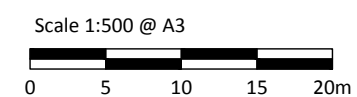
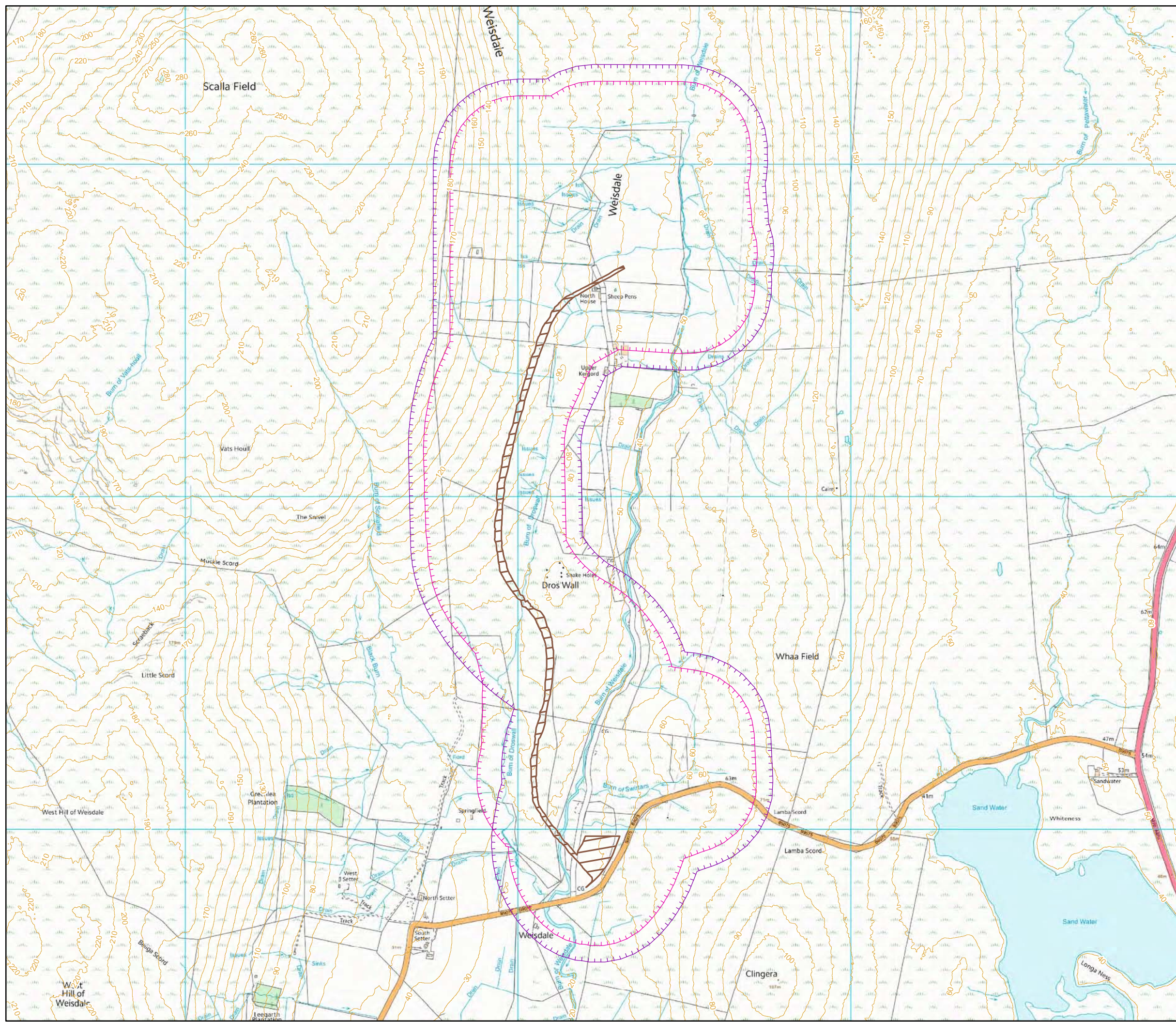





Figure 3.4
Proposed Construction
Compound Layout



Key

-  Infrastructure footprint
-  Phase 1/NVC survey boundary
-  Otter survey boundary

Scale 1:11,000 @ A3





Figure 4.1
ECOLOGICAL SURVEY AREA OVERVIEW